

CONVEYING IDEAS 5



- Why pet food palatant coating in dry pet food is critical
- How process pigging keeps pneumatic conveying lines clear
- New technology: Global Cleanable Airlock (GCA) designed for sanitary processes

Pet food palatant coating process

Before the palatant coating process is covered, it may be best to understand why it is required for pet food.

Since a pet's natural diet involves meat proteins, they prefer their food to have meat flavor. Pet food palatant, sometimes referred to as "digest" because it is made with proteins that are enzymatically broken down, adds flavor enhancement to make kibble more enticing to pets so they readily consume the dry pet food that has been carefully formulated for optimum nutrition. Palatant is typically added to the kibble after it has been dried. It can be added in liquid or dry form; however, the dry form is more common.

The addition of a palatant does require some care. An enrober is normally used to "enrobe" the kibble with fats, oils, and both liquid and dry palatants. There are three basic types of enrobers: batch, continuous ribbon, and continuous drum. Each type has advantages in certain areas over the other.

A weighbelt feeder is typically used to introduce the dried kibble into the continuous style enrobers. The use of a weighbelt offers less product degradation than some other feeder devices (like a screw feeder) and provides a controlled flow of kibble that the other topicals can be accurately metered from. Palatants are dosed at low formulation percentages so even a few seconds of under-applied palatant could lead to multiple bags of product that a pet doesn't readily consume, possibly resulting in customer complaints or lost customers. Controlling and measuring the dry feed rate of the uncoated kibble just before the enrobing process ensures that any minor process fluctuations before the enrober can be accounted for and the proper amount of palatant applied.

The weighbelt utilizes a weighing device, usually a load cell, to determine how much material is on the belt. The speed of the belt is also required for the weighbelt controller to calculate the flowrate of the kibble. A speed sensor or encoder is used by the weight controller to collect this information.

The weighbelt feeder is typically a sanitary design and is either open or enclosed, depending upon the requirements of the manufacturing facility. Enclosed design offers protection to operators in case the kibble is still at an elevated temperature and from foreign

materials or contaminants being introduced into the production stream. The open-design weighbelt provides easier access and therefore, quicker and more thorough cleaning of its components.

Once the kibble is introduced into the enrober, the palatant must then be applied. A screw feeder is frequently used to apply the dry palatant. A loss-in-weight (LIW) screw feeder is most commonly used for this application as the amount or weight of palatant being added is easily determined and controlled.

In the case of drum-style continuous enrobers, the LIW feeder requires an extended discharge tube to reach into the drum. The LIW feeder would be positioned so the discharge tube is inserted into the open discharge end of the drum. The screw feeder should incorporate a spreading nozzle (discharge tube with a series of adjustable slotted openings) to assist in distributing the dry palatant onto the tumbling bed of kibble. The spreading nozzle produces a curtain of dry palatant, thus improving the coating of each kibble. Care should be taken to ensure that the tumbling product does not contact the spreading nozzle as it will interfere with the weighing of the palatant.



A weighbelt feeder offers less kibble degradation than other feeder devices, such as a screw feeder.



Depending on the requirements of the manufacturing facility, an open-design weightbelt feeder allows for a quicker and more thorough cleaning of its components.

Batch and continuous ribbon enrobers use LIW feeders with a more standard configuration, but in all cases high-end finish and ease of breakdown for inspection and cleaning is very important for these feeders, just as it is with the weighbelt feeder. This is due to the fact that there is no bacterial kill step after the extruder, so any contamination could proliferate if left unchecked.

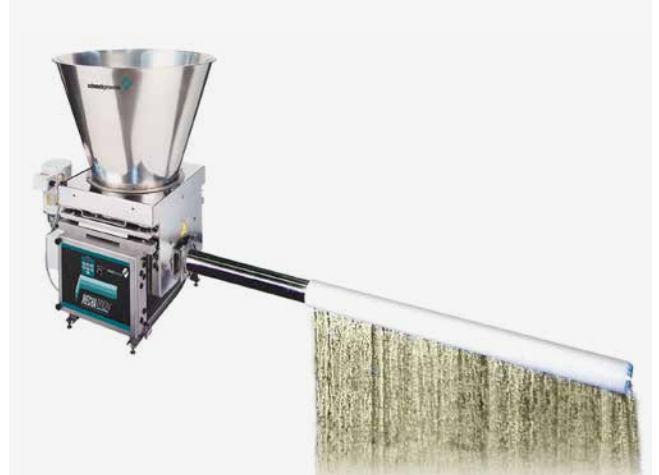

As process variations occur, feeder output is automatically adjusted to follow the amount of kibble being introduced by the weighbelt feeder to ensure a consistent coating is applied.

Palatant application is a very important process within any pet food plant. One test consumers use to evaluate the quality of their pet's food is whether or not their pet appears to enjoy eating it. Millions of dollars are spent on feeding trials, "tastes better" advertising campaigns, and new varieties of improved palatants with that goal in mind. Precise measurement and dosing of both feed and palatant are crucial steps to make sure that every feeding consistently passes this test.

**By Roger Smith,
Applications Engineer, Schenck Process
r.smith2@schenckprocess.com**

How process pigging keeps pneumatic conveying lines clear

Pigging addresses sanitation in pneumatic conveying systems, but the technology to operate it in a safe and controlled manner has been lacking. Until now.

Process pipelines are often in need of a methodology to address issues of build-up and cross contamination. Pigging is a common technique used in liquids and oil/gas to address the concerns of both residual material and unwanted accumulation on the interior surface. A projectile (pig) is launched through the pipeline in order to scour the pipe wall and drive all contamination to the destination.

The pigging process can also be applied to pneumatic conveying pipelines to mitigate build-up or ensure that the pipe surface is clean. Historically, this would be a manual process where a user would encounter:

- No access to the pipe – the pipeline would need to be broken and the pig inserted manually.
- Lack of control – the air supply used to drive the pig would be of varying volume and pressure.
- Difficult to retrieve – the pig is deposited in a place difficult to access or is not easy to reach.
- Not safe – lack of projectile control with potentially high pressures results in unsafe conditions

A process pigging solution for pneumatic conveying lines would automate the launching and catching functions while controlling the projectile so that it can be operated in a safe environment.

Launcher

The launching device for the pig provides an automated method to insert the pig into the conveying line, while not compromising safety or the normal operation of the system. The launching unit allows the operator to open an access hatch (with proper safety features) and insert the pig freely into the staging tube. Once the hatch is closed, a ram is activated to drive the pig into the conveying line connection. Motive air is simultaneously turned on to begin the process of driving the pig through the conveying line. While the ram is extended, the launcher is sealed to prevent air loss and allow the conveying system to operate normally while the pigging process is not in use.

Pneumatic conveying systems introduce a unique challenge to the piping system when there is a rotary

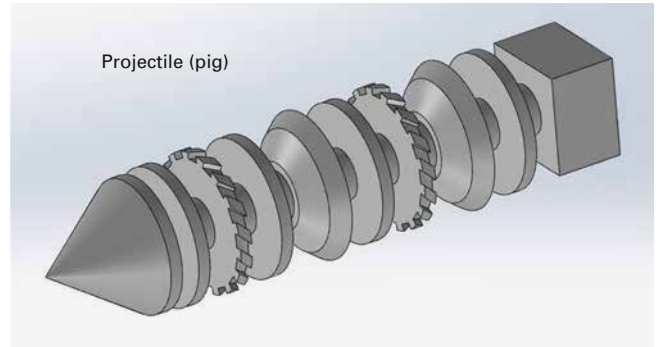

To keep conveying lines clean and clear, a projectile is used to drive all contamination out of the system.

valve (airlock) at the feedpoint. This process launches the pig from the clean air side of the airlock. This makes the pipe connections more sanitary since the launcher never comes into contact with the contaminating material. In this design, the pig passes beneath the airlock and continues into the conveying line. Due to pressure limitations and air loss as a result of airlock leakage, the pipeline is then isolated once the pig passes the feedpoint. Motive air is then shifted downstream of the isolation point, and the pig continues down the pipeline to the catcher.

Catcher

The catching unit is a device that can safely receive the pig as well as provide adequate access to recover it. For the catcher to do this safely, it must disentrain the projectile and vent the pressurized air accumulated behind. As the pig moves down the conveying line, the pipe volume behind it fills with air pressurized to the motive pressure needed to drive the pig. Therefore, the volume and pressure of air to be relieved will vary by line length in addition to the type of cleaning being conducted. To properly control the venting of the air, the pig catcher is pressure-rated, restricts the volume of air exhausting, and filters it before returning it to the atmosphere. As the pig enters the catcher, the projectile and the material being cleaned drop to separate areas of the unit while the air is vented. The pig is then available for retrieval through an access door.

It is possible to drive the pig into the existing receiver for the conveying line; however, this approach lacks three

main features of the dedicated catcher. First, it is unlikely that the existing receiver has the correct access. The pig will fall to the lowest point in the vessel, so it would be luck if an access door existed and it was placed where an operator could reach. Confined space entry further complicates this issue.

Second, the receiver may not be able to properly handle the venting requirements. Filters are designed with an airflow and pressure in mind. In this case, the receiver will experience a surge of air (as described above) and the vessel will pressurize to varying degrees along with the air surges. The effects of this surge may be benign, but the unpredictable nature creates a safety concern.

Finally, the material scoured from the convey line continues to the receiver, in which case it remains in the process. It is unlikely that this material is the same as the conveyed material or acceptable to the process. Therefore, if it does end up in the receiver, it must be separated later. The difficulty and risk of these factors necessitates the dedicated catcher in many cases.

Since the catcher is a separate device, the pig must be directed via the convey line to this other destination. A diverter valve placed adjacent to the receiver serves the purpose of redirecting the pipe path while the system is in a cleaning mode. Once diverted, additional piping takes the pig to the catcher so that the catcher may be placed in an accessible area that is convenient for the plant.

Piping & Projectile

For the pigging system to operate reliably and effectively, the pig must be selected so that it works with the piping and can address the type of build-up occurring in the line. The pig is suited for the piping primarily in terms of diameter. The dimensions of the pig will dictate how much interaction occurs between it and the pipe wall, as well as the pressure required to drive it through the system. In other words, if the pig has more wall contact and is made of a more robust material, it will do a better job of cleaning tough build-up. It will also require more pressure and flow to reliably pass through the convey pipe. Therefore, there is a gradient of pig features and materials of construction that can be applied depending on the application. The end result is a pigging process that balances cleaning effectiveness with operating pressure to achieve the desired level of pipe cleanliness.

The piping system itself is another consideration. A new piping system can be designed to include the desired attributes that facilitate the pigging process. An existing pipeline must be analyzed to determine if it can enable a pig to pass through in a proper fashion. A restriction in the pipe diameter (transition, diverter, etc.) will create a rigid barrier, in which case the pig will become lodged (or at least require a pressure increase to force it through). An enlarged diameter or variation in the shape of the piping will create areas of non-contact. While cleaning will not occur in these areas, a bigger concern is that the motive air will easily pass by and the pig will halt its progress, possibly becoming stuck. These features of the pipeline (new or existing) relate to the reliability of the pigging process.

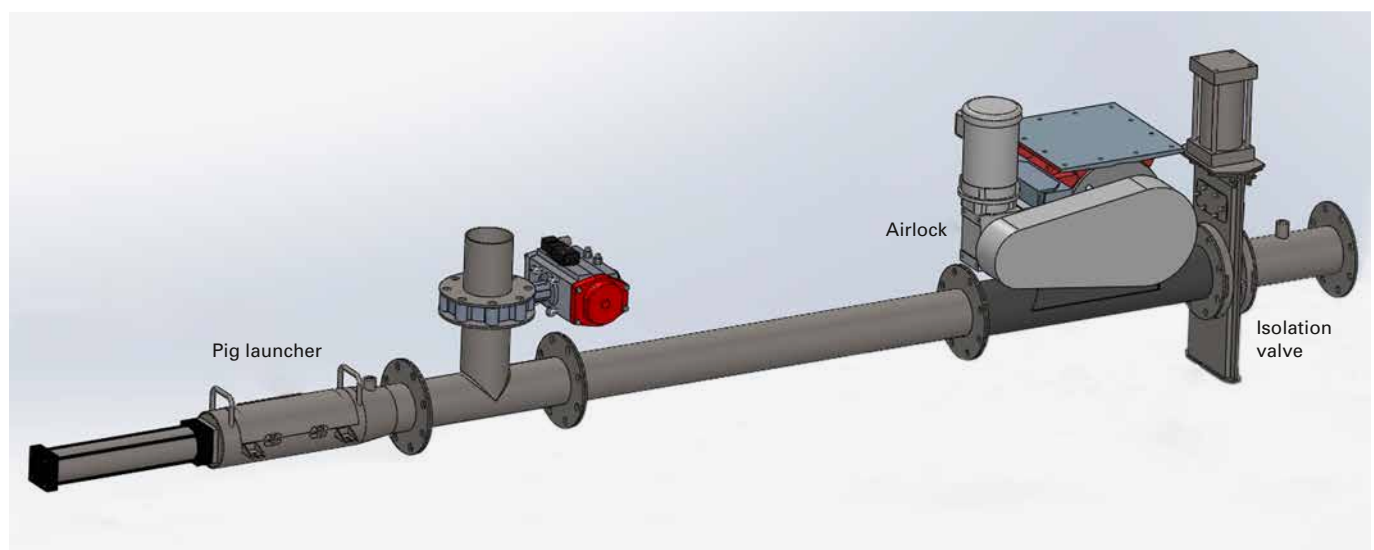

The launching unit allows the operator to open an access hatch (with proper safety features) and insert the pig into the staging tube. Once the hatch is closed, a ram is activated to drive the pig into the conveying line.

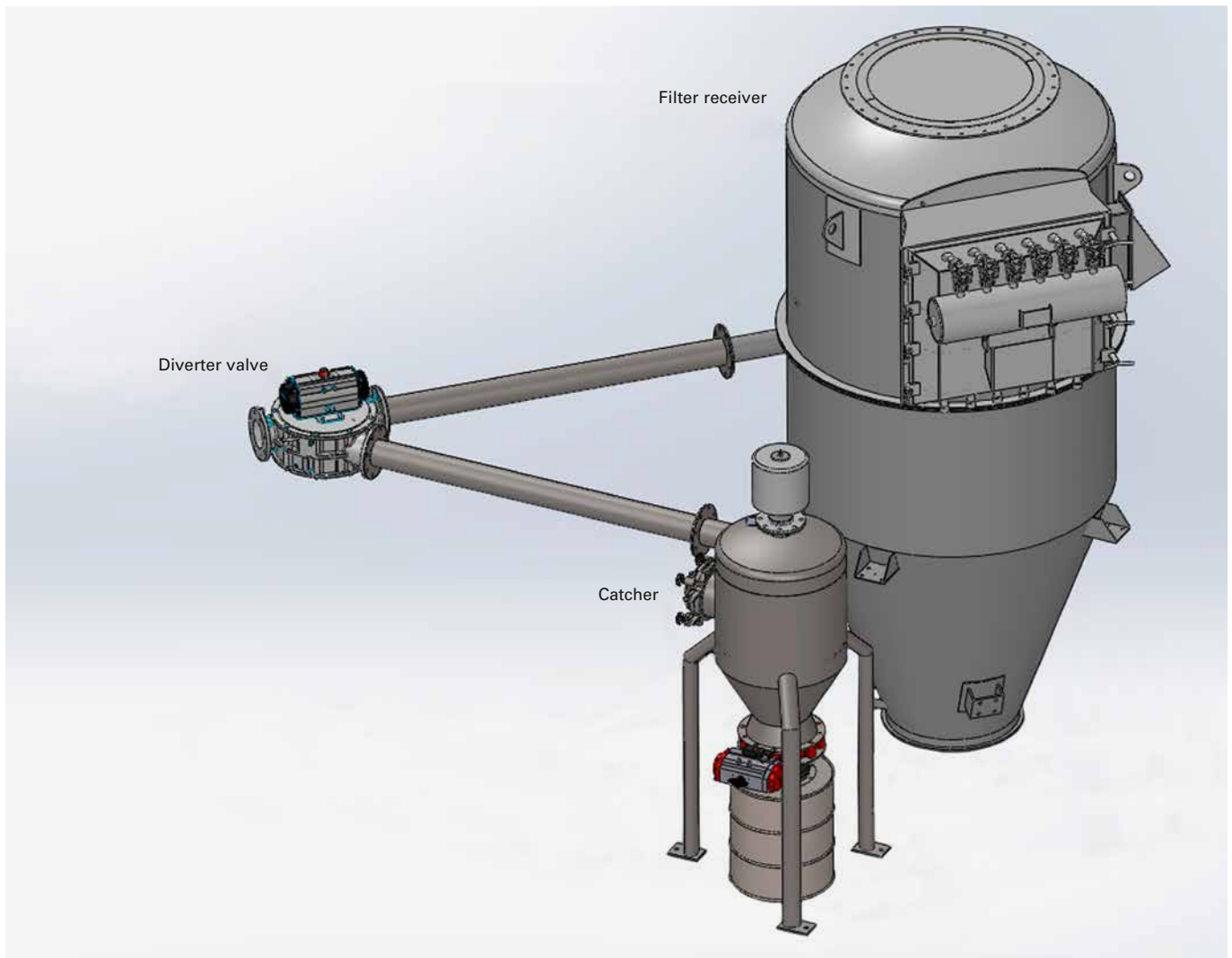

A successful pigging process always balances cleaning effectiveness with operating pressure to achieve the desired level of pipe cleanliness.

Other factors, such as the coupling type, will contribute to the effectiveness. A typical compression coupling provides ample recess in the pipe joint for material to accumulate. The pig will not be able to get into the joint gap to provide cleaning. Therefore, if this level of cleanliness is desired, then a machined joint (no-ledge coupling) must be considered. In summary, the condition and design of the piping system will play a large role in the pigging process and must be taken into account.

While pigging is currently used to address build-up and sanitation in pneumatic conveying systems, the technology to operate it in a safe and controlled manner has been lacking. A properly designed system can incorporate equipment and controls to make the pigging process reliable, safe and effective.

**By Jonathan Thorn,
Executive Director, Process Technology,
Schenck Process, j.thorn@schenckprocess.com**

Spotlight: new technology

Global Cleanable Airlock (GCA) is designed for sanitary processes

The new Global Cleanable Airlock (GCA) is ideal for applications where dry raw or finished products are being handled in a pet food manufacturing process and where inspection or system clean-out are required. Because the GCA is designed for high process rates and possesses a number of features suited for sanitary processes, the airlock is perfect for pet food applications.

Two models of the GCA consist of a standard and a demountable unit. The standard model is a round inlet, round outlet rotary valve, which incorporates seals and product contact surfaces that meet food safety requirements. The demountable unit is designed with a rail system that simplifies removal of the endplate/rotor assembly from the housing, providing access to the

internal valve cavity, rotor pockets and all other product contact areas for quick and easy cleaning.

Other key features of the GCA include:

- Easy access to seals with rotor removed from the endplate
- All stainless steel construction with the exception of the endplate bearings
- Housing and endplates designed for 10 Bar explosion shock resistance
- FDA- and EC 1935/2004-approved materials of construction in product contact areas
- Oversized rotor shaft that creates a naturally radiused rotor pocket for more complete product release



Designed for applications where dry raw or finished products are being handled and when inspection or system clean-out are required



Schenck Process LLC
7901 NW 107th Terrace
Kansas City, MO 64153 USA
T 816-891-9300
mktg@schenckprocess.com
www.schenckprocess.com

Schenck Process Europe GmbH
Pallaswiesenstr. 100
64293 Darmstadt, Germany
T +49 61 51-15 31 0
sales@schenckprocess.com
www.schenckprocess.com